

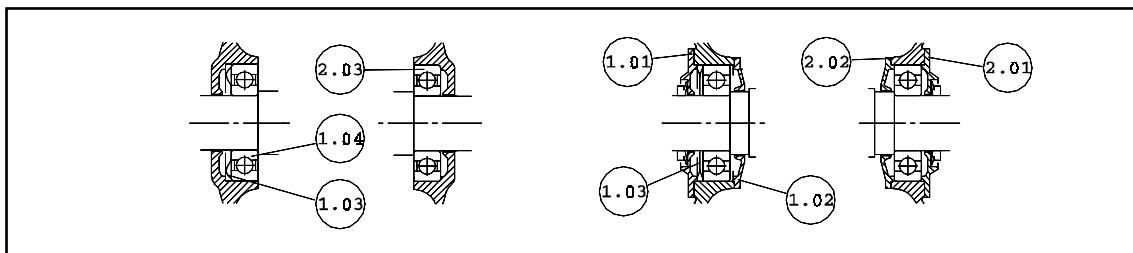

Drehstrom-Bremsmotoren mit Käfigläufer

Three-phase break motors with squirrel-cage rotor

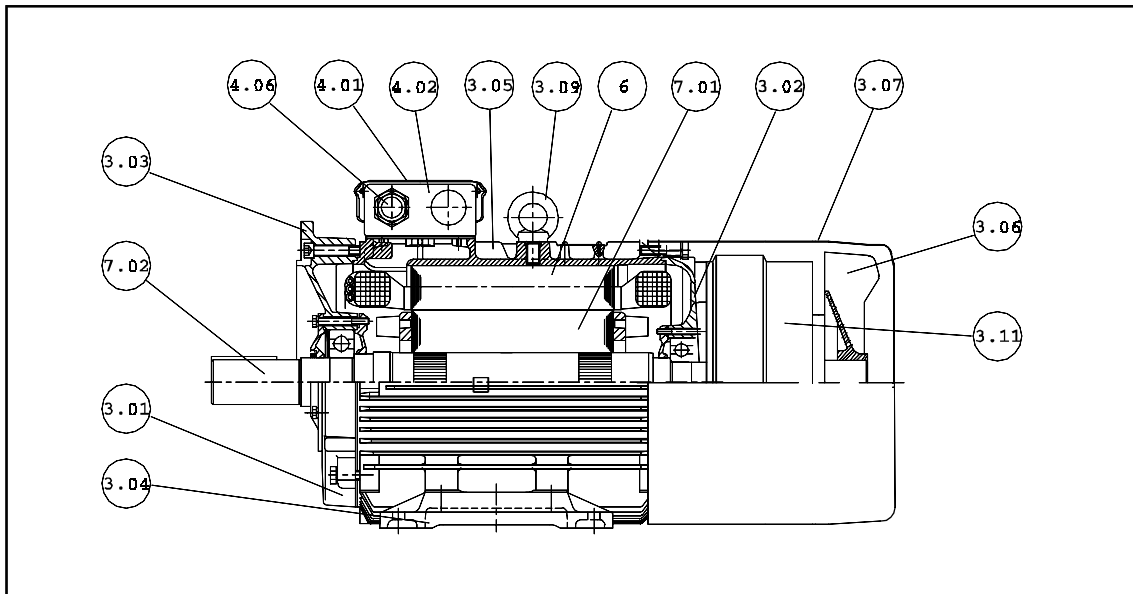

Lagerung Standardausführung / Bearing system standard execution
 ohne Festlager / without fixed bearing mit Festlager / with fixed bearing

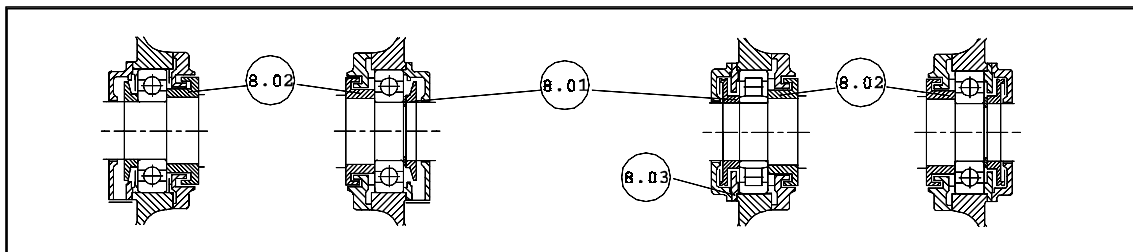

Nachschmiereinrichtung / regreasing device
 ohne Leitscheibe / without guide disc mit Leitscheibe / with guide disc

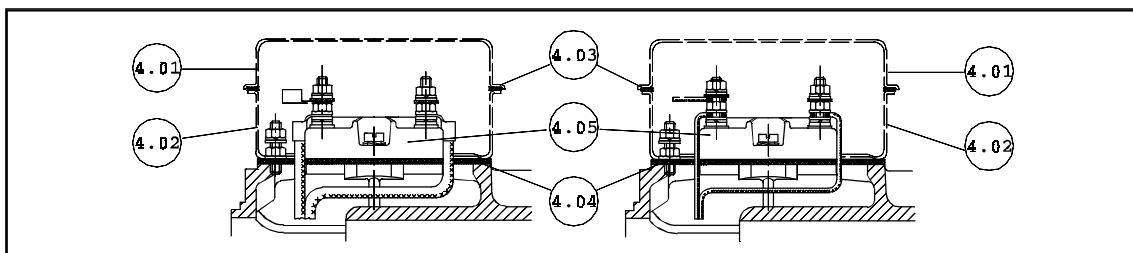

Anschlußsystem für / connection system for
 Kabelschuhanschluß / connection with cable eye Ösenanschluß / connection with eyelet