



DESPIECE ORIENTATIVO

ERSATZTEILLISTE NUR ZUR ORIENTIERUNG

THE SPARE PARTS LIST IS FOR GUIDANCE ONLY

VUE EN COUPE

Series LPC
Serien LPC
Series LPC
Séries LPC

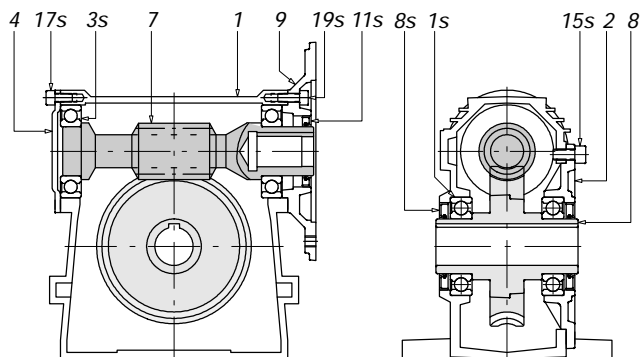

Detalle LPC-LBC 49/200-19 - LPC-LBC 61/250-28

Ver resto de referencias en LPC-LBC

Detail LPC-LBC 49/200-19 - LPC-LBC 61/250-28

Restliche Bezeichnungen siehe LPC-LBC

Detail LPC-LBC 49/200-19 - LPC-LBC 61/250-28

The remaining references are identical to those shown in LPC-LBC

Détail LPC-LBC 49/200-19 - LPC-LBC 61/250-28

Reste des références voir LPC-LBC

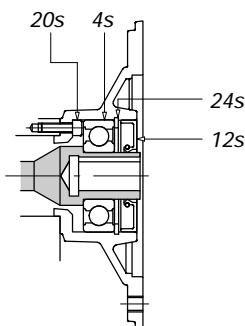

Series LBC Ver resto de referencias en LPC

Series LBC Restliche Bezeichnungen siehe LPC

Series LBC The remaining references are identical to those shown in LPC

Séries LBC Reste des références voir LPC

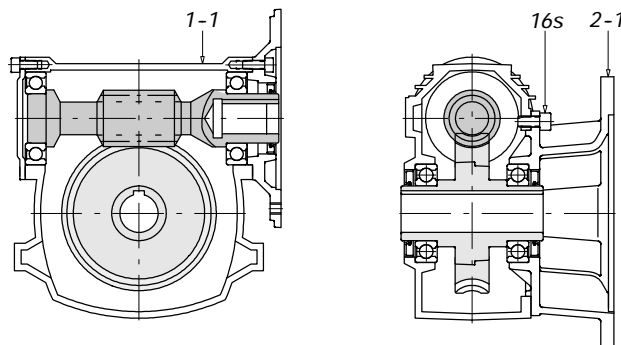

Detalle LPC-LBC 130

Ver resto de referencias en LPC-LBC

Detail LPC-LBC 130

Restliche Bezeichnungen siehe LPC-LBC

Detail LPC-LBC 49/200-19 - LPC-LBC 61/250-28

The remaining references are identical to those shown in LPC-LBC

Détail LPC-LBC 130

Reste des références voir LPC-LBC

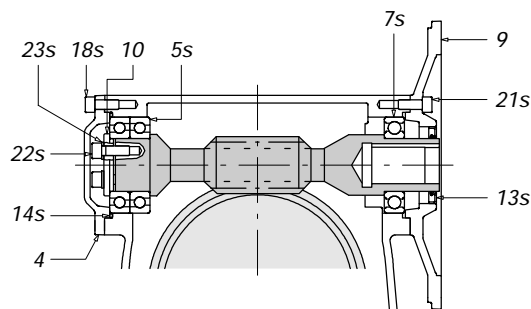

Ref. Pos.-Nr. Ref. Réf.	Denominación Bezeichnung Denomination Dénomination	Denominación Bezeichnung Denomination Dénomination	Denominación Bezeichnung Denomination Dénomination	Denominación Bezeichnung Denomination Dénomination
1	Caja patas	Getriebegehäuse	Leg box	Boîlle pattes
1-1	Caja brida	Getriebegehäuse	Flange box	Boîlle bride
2	Tapa salida	Getriebedeckel- abtriebsseitig	Output cover	Couvercle sortie
2-1	Tapa salida brida	Getriebedeckel- Flansch	Flange output cover	Couvercle sortie bride
4	Tapeta ciega visinfín	Abdeckung	Blind cover endless screw	Chapeau aveugle vis sans fin
7	Visinfín	Schnecke	Endless screw	Vis sans fin
8	Conjunto corona eje salida	Bronzerad Abtriebswelle	Crow-output shaft unit	Ensemble couronne-axe sortie
9	Brida unión	Motorflansch	Motor flange	Bride moteur
10	Arandela apriete	Sicherungsring	Tightening washer	Rondelle de serrage
1s	Rodamiento	Wälzlager	Bearing	Roulement
3s	Rodamiento	Wälzlager	Bearing	Roulement
4s	Rodamiento	Wälzlager	Bearing	Roulement
5s	Rodamiento	Wälzlager	Bearing	Roulement
7s	Rodamiento	Wälzlager	Bearing	Roulement
8s	Retén	Wellendichtring	Oil seal	Joint

Ref. Pos.-Nr. Ref. Réf.	Denominación Bezeichnung Denomination Dénomination	Denominación Bezeichnung Denomination Dénomination	Denominación Bezeichnung Denomination Dénomination	Denominación Bezeichnung Denomination Dénomination
11s	Retén	Wellendichtring	Oil seal	Joint
12s	Retén	Wellendichtring	Oil seal	Joint
13s	Retén	Wellendichtring	Oil seal	Joint
14s	Arandela tórica	Sicherungsring	O-ring washer	Rondelle thorique
15s	Tornillo cilíndrico	Zylinderschraube	Cylinder screw	Vis cylindrique
16s	Tornillo cilíndrico	Zylinderschraube	Cylinder screw	Vis cylindrique
17s	Tornillo cilíndrico	Zylinderschraube	Cylinder screw	Vis cylindrique
18s	Tornillo cilíndrico	Zylinderschraube	Cylinder screw	Vis cylindrique
19s	Tornillo cilíndrico	Zylinderschraube	Cylinder screw	Vis cylindrique
20s	Tornillo cilíndrico	Zylinderschraube	Cylinder screw	Vis cylindrique
21s	Tornillo cilíndrico	Zylinderschraube	Cylinder screw	Vis cylindrique
22s	Tornillo cilíndrico	Zylinderschraube	Cylinder screw	Vis cylindrique
23s	Arandela de muelle	Scheibe	Spring washer	Rondelle de ressort
24s	Anillo elástico	Sicherungsring	Elastic ring	Anneau élastique