

UNITEN



- Muelle - 1
- Junta eje (O-Ring) - 2
- Armadura - 3
- Junta giratoria (O-Ring) - 4
- Anillo de cierre giratorio - 5
- Anillo de cierre fijo - 6
- Junta fija (O-Ring) - 7
- Tornillos de fijación - 8
- Manguito - 9

- Estacionaria con anclaje - CL
- Estacionaria sin anclaje - CC

UNITEN 85

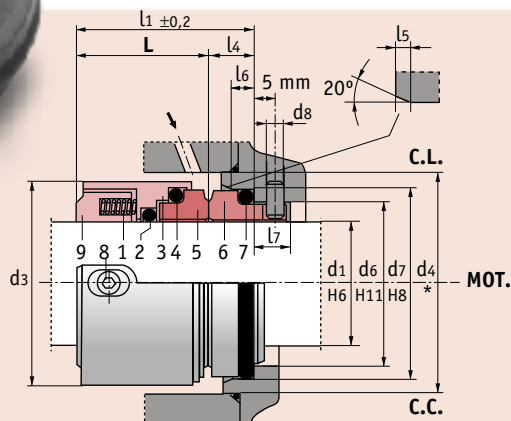

UNITEN 85												EN 12756 / ISO 3069											
d ₁	d ₆	d ₇	d ₃	d ₄	l ₁	L	l ₄	l ₆	l ₅	d ₈	l ₇												
12	19	23	22,5	24	25	18	7	4	1,5	3	8,5												
14	21	25	24,5	26	29	22	7	4	1,5	3	8,5												
16	23	27	28,5	28	30	23	7	4	1,5	3	8,5												
18	27	33	32,5	34	34	24	10	5	2	3	9												
20	29	35	32,5	36	35	25	10	5	2	3	9												
22	31	37	37	38	35	25	10	5	2	3	9												
24	33	39	37	40	35	25	10	5	2	3	9												
25	34	40	41	42+	36	26	10	5	2	3	9												
28	37	43	47	48+	36	26	10	5	2	3	9												
30	39	45	47	48+	36	26	10	5	2	3	9												
32	42	48	47	48	36	26	10	5	2	3	9												
33	42	48	48	49	40	30	10	5	2	3	9												
35	44	50	57	58+	40	30	10	5	2	3	9												
38	49	56	64	65+	45	32	13	6	2	4	9												
40	51	58	64	65+	45	32	13	6	2	4	9												
43	54	61	64	65+	45	32	13	6	2	4	9												
45	56	63	69	70+	45	32	13	6	2	4	9												
48	59	66	69	70+	45	32	13	6	2	4	9												
50	62	70	75	76+	47,5	33,5	14	6	2,5	4	9												
53	65	73	75	76+	47,5	33,5	14	6	2,5	4	9												
55	67	75	75	76+	47,5	33,5	14	6	2,5	4	9												
58	70	78	83	84+	52,5	38,5	14	6	2,5	4	9												
60	72	80	83	85	52,5	38,5	14	6	2,5	4	9												
63	75	83	88	89+	52,5	38,5	14	6	2,5	4	9												
65	77	85	88	90	52,5	38,5	14	6	2,5	4	9												
68	81	90	93	94+	60	44	16	7	2,5	4	9												
70	83	92	93	95	60	44	16	7	2,5	4	9												
75	88	97	98	104	60	44	16	7	2,5	4	9												